

O P E R A T I N G I N S T R U C T I O N S

GA 10.211 / 4.02

Cat. No.

140 00      141 00

140 01      141 01

140 10      141 10

140 11      141 11

from software version V 2.1

---

**ULTRATEST UL 200**

Helium Leak Detector

---



O P E R A T I N G I N S T R U C T I O N S

GA 10.211 / 4.02

Cat. No.

140 00      141 00

140 01      141 01

140 10      141 10

140 11      141 11

from software version V 2.1

---

**ULTRATEST UL 200**

Helium Leak Detector

---



---

**INFICON Service**

If equipment is returned to INFICON, indicate whether the equipment is free of substances damaging to health or whether it is contaminated. If it is contaminated also indicate the nature of the hazard. INFICON must return any equipment without a Declaration of Contamination to the sender's address. A copy of this declaration can be found at the end of these Operating Instructions.

**General Remarks**

We reserve the right to alter the design or any data given in these Operating Instructions.

The illustrations are not binding.

**Note**

More detailed information can be found, besides these Operating Instructions, in the comprehensive Handbook for the UL 200 which is also included with the instrument.

**Contents**

	<b>Page</b>
1	Notes concerning electrical safety . . . . . 3
2	Purpose . . . . . 3
3	Installation and initial start-up . . . . . 4
4	Operation . . . . . 6
4.1	The hand unit . . . . . 6
4.2	The control panel . . . . . 8
5	Connections . . . . . 11
6	Short description of the software menu of the UL 200 . . . . . 14
7	Vacuum leak detection method . . . . . 21
8	Sniffer leak detection method . . . . . 21
9	Partial flow operation . . . . . 22
10	Switching the instrument off . . . . . 22

---

**INFICON Service**

If equipment is returned to INFICON, indicate whether the equipment is free of substances damaging to health or whether it is contaminated. If it is contaminated also indicate the nature of the hazard. INFICON must return any equipment without a Declaration of Contamination to the sender's address. A copy of this declaration can be found at the end of these Operating Instructions.

**General Remarks**

We reserve the right to alter the design or any data given in these Operating Instructions.

The illustrations are not binding.

**Note**

More detailed information can be found, besides these Operating Instructions, in the comprehensive Handbook for the UL 200 which is also included with the instrument.

**Contents**

	<b>Page</b>
1	Notes concerning electrical safety . . . . . 3
2	Purpose . . . . . 3
3	Installation and initial start-up . . . . . 4
4	Operation . . . . . 6
4.1	The hand unit . . . . . 6
4.2	The control panel . . . . . 8
5	Connections . . . . . 11
6	Short description of the software menu of the UL 200 . . . . . 14
7	Vacuum leak detection method . . . . . 21
8	Sniffer leak detection method . . . . . 21
9	Partial flow operation . . . . . 22
10	Switching the instrument off . . . . . 22

---

# 1 Notes Concerning Electrical Safety

- This instrument meets the requirements of the CE standard.
- It thus conforms with the requirements of the previous standards, like VDE (EC...).

## Warning



Only 3-core mains cables with protective ground conductor must be used. The instrument must not be operated with an unconnected ground conductor.

# 2 Purpose

The ULTRATEST UL 200 is a helium leak detector. It may be employed for the detection of leaks in test samples,

- when these have been evacuated and are sprayed with helium from the outside. For this the UL 200 requires a vacuum link with the test sample. The evacuation itself may be performed through the UL 200 alone in the case of small samples (vacuum method). In the case of larger volumes this will require additional support by a further pump system (vacuum method with partial flow operation).
- when a helium overpressure prevails in these and when using a sniffer probe to search the outside of the test sample (sniffer method).

## Caution



The UL 200 must not be operated while standing in resting or flowing water, or dripping water. The same applies to all other kinds of liquid. Avoid contact with bases, acids and solvents, as well as exposure to extreme climatic conditions.

---

# 1 Notes Concerning Electrical Safety

- This instrument meets the requirements of the CE standard.
- It thus conforms with the requirements of the previous standards, like VDE (EC...).

## Warning



Only 3-core mains cables with protective ground conductor must be used. The instrument must not be operated with an unconnected ground conductor.

# 2 Purpose

The ULTRATEST UL 200 is a helium leak detector. It may be employed for the detection of leaks in test samples,

- when these have been evacuated and are sprayed with helium from the outside. For this the UL 200 requires a vacuum link with the test sample. The evacuation itself may be performed through the UL 200 alone in the case of small samples (vacuum method). In the case of larger volumes this will require additional support by a further pump system (vacuum method with partial flow operation).
- when a helium overpressure prevails in these and when using a sniffer probe to search the outside of the test sample (sniffer method).

## Caution



The UL 200 must not be operated while standing in resting or flowing water, or dripping water. The same applies to all other kinds of liquid. Avoid contact with bases, acids and solvents, as well as exposure to extreme climatic conditions.

---

### 3 Installation and Initial Start-Up

Please remove the separately supplied parts from the packaging. Retain the packaging so that the UL 200 may be safely packaged when shipping it at some later date.

Convince yourself that the instrument is undamaged on the outside.

#### Caution



Convince yourself that the instrument is set to the mains voltage used in your country.

#### Caution



The gas ballast and exhaust connections on the UL 200 are sealed with a yellow screw-on stopper prior to shipping. **See Fig. 1.**

**Before starting up the UL 200, these stoppers must be removed.**

When planning to ship the UL 200 again, the yellow stoppers must be screwed into the gas ballast and exhaust connections once more.

Use the mains cable to connect the UL 200 to the mains.

When wanting to operate the UL 200 in connection with a partial flow pump set, please also read Section 9. The method of sniffer leak detection is described in Section 8. The method of vacuum leak detection is described in Section 7

Now the UL 200 is ready for operation. Before switching the instrument on, it should be brought to its „work place“. The instrument should not be moved while it is running; should this be necessary move it softly and with care. Jerks and vibrations should be avoided under all circumstances.

As soon as the UL 200 has been switched on, it will begin to run up. This will take about 2 to 3 minutes depending on the temperature and the way in which the instrument was treated before switching it on. During the run up period the built-in software version number will be displayed, followed by an electronic self-test and acceleration of the built-in turbomolecular pump up to its nominal speed.

Completion of run-up is indicated by a brief acoustic signal. The UL 200 will remain in the „standby“ mode.

---

### 3 Installation and Initial Start-Up

Please remove the separately supplied parts from the packaging. Retain the packaging so that the UL 200 may be safely packaged when shipping it at some later date.

Convince yourself that the instrument is undamaged on the outside.

#### Caution



Convince yourself that the instrument is set to the mains voltage used in your country.

#### Caution



The gas ballast and exhaust connections on the UL 200 are sealed with a yellow screw-on stopper prior to shipping. **See Fig. 1.**

**Before starting up the UL 200, these stoppers must be removed.**

When planning to ship the UL 200 again, the yellow stoppers must be screwed into the gas ballast and exhaust connections once more.

Use the mains cable to connect the UL 200 to the mains.

When wanting to operate the UL 200 in connection with a partial flow pump set, please also read Section 9. The method of sniffer leak detection is described in Section 8. The method of vacuum leak detection is described in Section 7

Now the UL 200 is ready for operation. Before switching the instrument on, it should be brought to its „work place“. The instrument should not be moved while it is running; should this be necessary move it softly and with care. Jerks and vibrations should be avoided under all circumstances.

As soon as the UL 200 has been switched on, it will begin to run up. This will take about 2 to 3 minutes depending on the temperature and the way in which the instrument was treated before switching it on. During the run up period the built-in software version number will be displayed, followed by an electronic self-test and acceleration of the built-in turbomolecular pump up to its nominal speed.

Completion of run-up is indicated by a brief acoustic signal. The UL 200 will remain in the „standby“ mode.

Depending on the operating mode, it is required that you read Section 7 (method of vacuum leak detection), Section 8 (method of sniffer leak detection) or Sec. 9 (leak detection in connection with a partial flow pump set).

**Caution**



Do not place the instrument on soft surfaces (expanded rubber, for example) as otherwise the air flow through the bottom is obstructed. Ensure adequate clearance also in the case of the other ventilation slits.

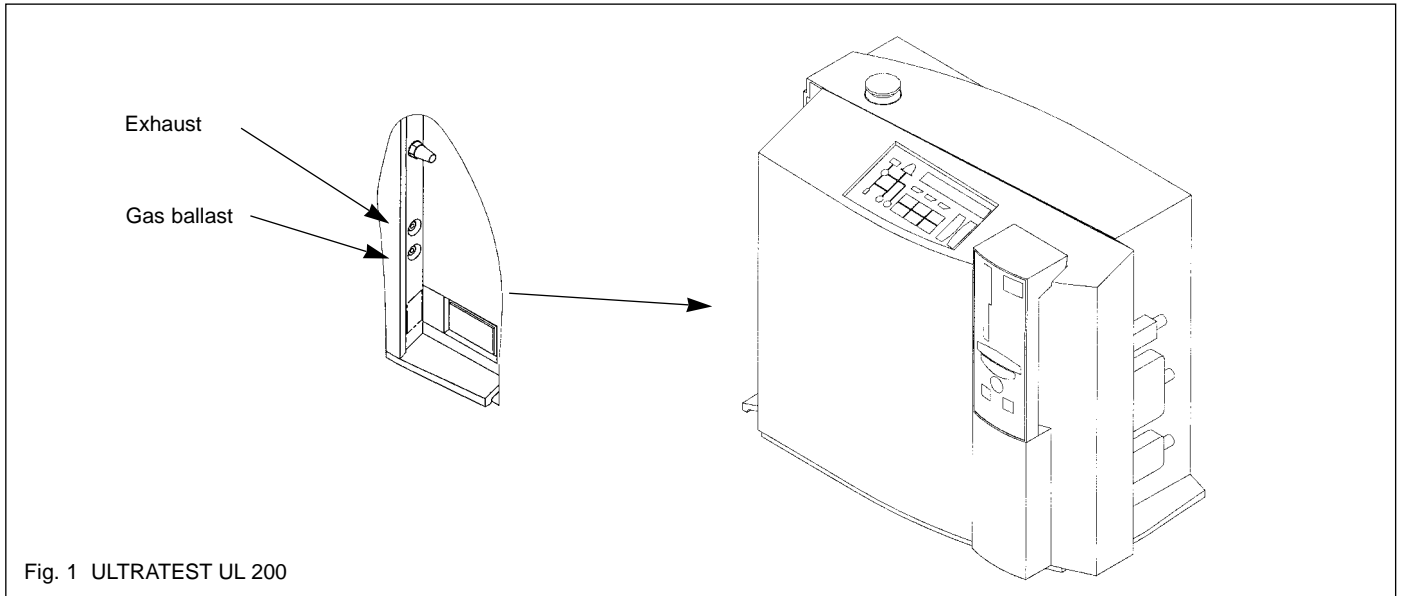

Fig. 1 ULTRATEST UL 200

Depending on the operating mode, it is required that you read Section 7 (method of vacuum leak detection), Section 8 (method of sniffer leak detection) or Sec. 9 (leak detection in connection with a partial flow pump set).

**Caution**



Do not place the instrument on soft surfaces (expanded rubber, for example) as otherwise the air flow through the bottom is obstructed. Ensure adequate clearance also in the case of the other ventilation slits.

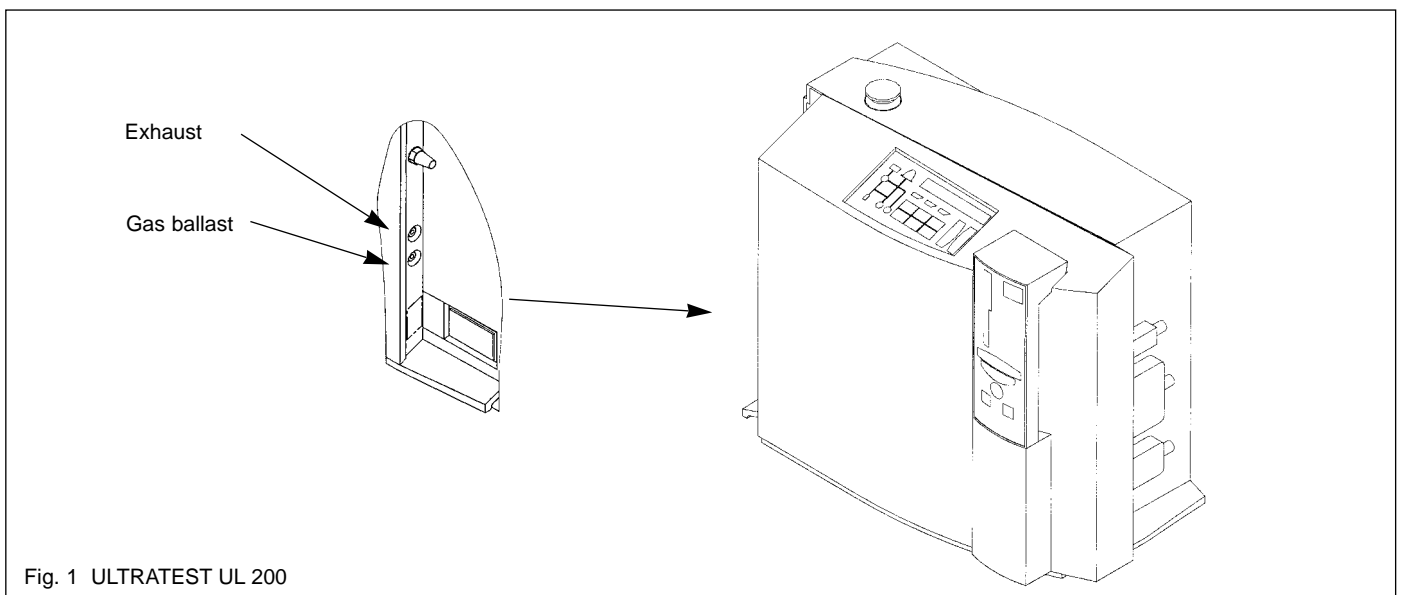

Fig. 1 ULTRATEST UL 200

---

## 4 Operation

The measurement process is exclusively controlled via the detachable hand unit (see Fig. 2) when not operating the instrument through the RS 232 interface or via the „Control“ inputs. The control panel (see Fig. 3) on the instrument itself permits the entry of special settings and modes.

### 4.1 The Hand Unit

#### Start

The measurement process is started by pressing the Start push-button (2/3). The instrument will be running a measurement as soon as the exponent comes on.

#### Stop / Vent

Pressing of this push-button (2/2) will interrupt a measurement which is in progress. When pressing this push-button for a longer period of time, the inlet of the UL 200 and thus also the connected test sample will be vented.

#### Zero

When pressing this push-button (2/1) the leak rate which is being measured at that moment will be taken as the background level and subtracted from all measurements which follow thereafter.

Pressing this push-button once more cancels the sup-

pression of the background level.

#### Arrow push-buttons

Operation of the two arrow push-buttons (2/10) and (2/11) increases or decreases the volume of the acoustic signal.

All other controls are used to display the measured results or modes of the instrument.

#### Light bars

The light bar (2/4) is divided into two sections. The upper section of this display indicates the currently measured leak rate within the displayed decade (exponent). The lower, more narrow section indicates  $1/10$ th increments of the displayed decade.

#### Exponent

This number (2/7) indicates the currently valid decade for the measured value.

Example:  $\boxed{-5}$  indicates the 10-5 range  
(equivalent to a factor of 0.00001)

#### Manual LED

When the automatic ranging mode has been switched off on the instrument („Manual“ push-button (1/11) on the control panel), LED (2/8) will light up. The exponent is then frozen independently of the actually measured value and may only be changed manually through the „Value“ push-button (3/6) on the control panel.

---

## 4 Operation

The measurement process is exclusively controlled via the detachable hand unit (see Fig. 2) when not operating the instrument through the RS 232 interface or via the „Control“ inputs. The control panel (see Fig. 3) on the instrument itself permits the entry of special settings and modes.

### 4.1 The Hand Unit

#### Start

The measurement process is started by pressing the Start push-button (2/3). The instrument will be running a measurement as soon as the exponent comes on.

#### Stop / Vent

Pressing of this push-button (2/2) will interrupt a measurement which is in progress. When pressing this push-button for a longer period of time, the inlet of the UL 200 and thus also the connected test sample will be vented.

#### Zero

When pressing this push-button (2/1) the leak rate which is being measured at that moment will be taken as the background level and subtracted from all measurements which follow thereafter.

Pressing this push-button once more cancels the sup-

pression of the background level.

#### Arrow push-buttons

Operation of the two arrow push-buttons (2/10) and (2/11) increases or decreases the volume of the acoustic signal.

All other controls are used to display the measured results or modes of the instrument.

#### Light bars

The light bar (2/4) is divided into two sections. The upper section of this display indicates the currently measured leak rate within the displayed decade (exponent). The lower, more narrow section indicates  $1/10$ th increments of the displayed decade.

#### Exponent

This number (2/7) indicates the currently valid decade for the measured value.

Example:  $\boxed{-5}$  indicates the 10-5 range  
(equivalent to a factor of 0.00001)

#### Manual LED

When the automatic ranging mode has been switched off on the instrument („Manual“ push-button (1/11) on the control panel), LED (2/8) will light up. The exponent is then frozen independently of the actually measured value and may only be changed manually through the „Value“ push-button (3/6) on the control panel.

**Key to Fig. 2**

- 1 ZERO push-button
- 2 STOP/VENT push-button
- 3 START push-button
- 4 Light bar display
- 5 Underflow indicator (below range)
- 6 Overflow indicator (above range)
- 7 Exponent
- 8 MANUAL LED
- 9 LOCK LED
- 10 Acoustic signal quieter
- 11 Acoustic signal louder

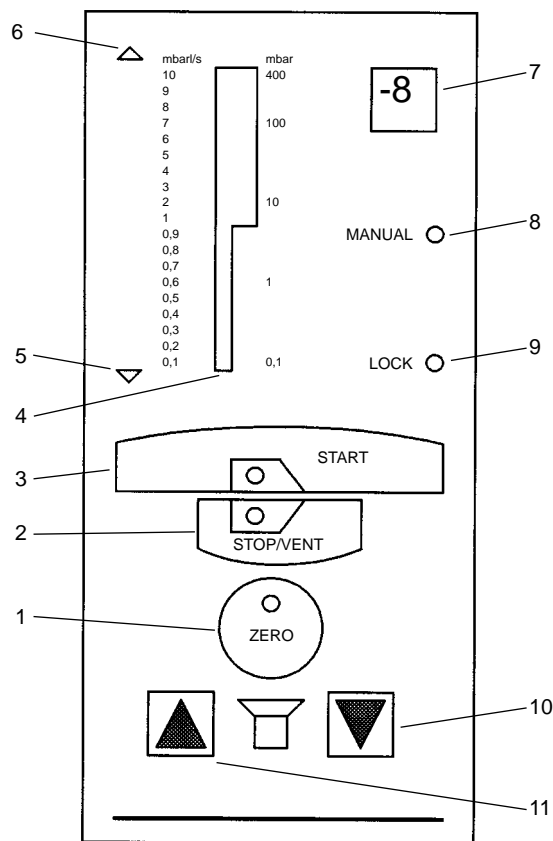

Fig. 2 Hand unit

**Key to Fig. 2**

- 1 ZERO push-button
- 2 STOP/VENT push-button
- 3 START push-button
- 4 Light bar display
- 5 Underflow indicator (below range)
- 6 Overflow indicator (above range)
- 7 Exponent
- 8 MANUAL LED
- 9 LOCK LED
- 10 Acoustic signal quieter
- 11 Acoustic signal louder

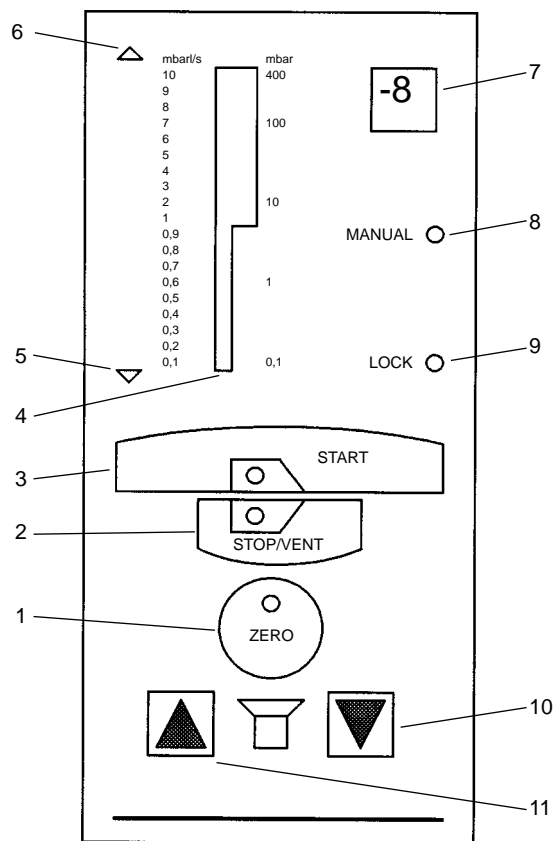

Fig. 2 Hand unit

---

### Lock LED

This LED (2/9) lights up when access to the controls of the UL 200 has been restricted (for details on this, refer to the handbook of the UL 200).

„▽, Δ“

The two yellow triangles (2/5) or (2/6) at the end of the light bar display (2/4) come on when the displayed measurement range (exponent) is exceeded either upwards or downwards.

### Note

In case the UL 200 has entered an error status, both LEDs with flash at the same time.

## 4.2 The Control Panel

The control panel has been divided into four sections

- a vacuum diagram (3/13) of the UL 200 with integrated light emitting diodes which indicate the valve settings and the operating modes of TMP pump and mass spectrometer
- an LCD panel (display) (3/2) which indicates measurement results, error messages, instrument modes and software functions
- a row of three trigger light emitting diodes (3/1), (3/3) and (3/4) which come on when selected trigger thresholds are exceeded

- a keyboard with partly integrated light emitting diodes for further adjustments (see following explanations).

### The „Scroll“ push-button

This push-button (3/5) is exclusively used to select the desired line of the software menu (refer also to the description for the „Menu“ push-button).

### The „Value“ push-button

This push-button (3/6) is used to enter numbers in the menu or change the exponent on the hand unit.

### The „Manual“ push-button

Pressing of this push-button (3/11) activates the manual range selection mode (LED lights up). After having pressed „Manual“, the rocker push-button „Value“ (3/6) may be used to enter the desired decade. Pressing the „Manual“ push-button once more returns the UL 200 to the autoranging mode.

### The „Cal“ push-button

This push-button (3/9) starts the calibration process in the UL 200.

When the UL 200 has been running in the „Standby“, or „Vent“ mode, an **internal calibration** of the UL 200 is run when pressing „Cal“, i.e. the instrument is calibrated with the aid of the built-in internal calibrated leak. This process is fully automatic and takes about 25 seconds. After completion, a corresponding message is displayed briefly on the LCD display. If there is no integrated calibrated

---

### Lock LED

This LED (2/9) lights up when access to the controls of the UL 200 has been restricted (for details on this, refer to the handbook of the UL 200).

„▽, Δ“

The two yellow triangles (2/5) or (2/6) at the end of the light bar display (2/4) come on when the displayed measurement range (exponent) is exceeded either upwards or downwards.

### Note

In case the UL 200 has entered an error status, both LEDs with flash at the same time.

## 4.2 The Control Panel

The control panel has been divided into four sections

- a vacuum diagram (3/13) of the UL 200 with integrated light emitting diodes which indicate the valve settings and the operating modes of TMP pump and mass spectrometer
- an LCD panel (display) (3/2) which indicates measurement results, error messages, instrument modes and software functions
- a row of three trigger light emitting diodes (3/1), (3/3) and (3/4) which come on when selected trigger thresholds are exceeded

- a keyboard with partly integrated light emitting diodes for further adjustments (see following explanations).

### The „Scroll“ push-button

This push-button (3/5) is exclusively used to select the desired line of the software menu (refer also to the description for the „Menu“ push-button).

### The „Value“ push-button

This push-button (3/6) is used to enter numbers in the menu or change the exponent on the hand unit.

### The „Manual“ push-button

Pressing of this push-button (3/11) activates the manual range selection mode (LED lights up). After having pressed „Manual“, the rocker push-button „Value“ (3/6) may be used to enter the desired decade. Pressing the „Manual“ push-button once more returns the UL 200 to the autoranging mode.

### The „Cal“ push-button

This push-button (3/9) starts the calibration process in the UL 200.

When the UL 200 has been running in the „Standby“, or „Vent“ mode, an **internal calibration** of the UL 200 is run when pressing „Cal“, i.e. the instrument is calibrated with the aid of the built-in internal calibrated leak. This process is fully automatic and takes about 25 seconds. After completion, a corresponding message is displayed briefly on the LCD display. If there is no integrated calibrated

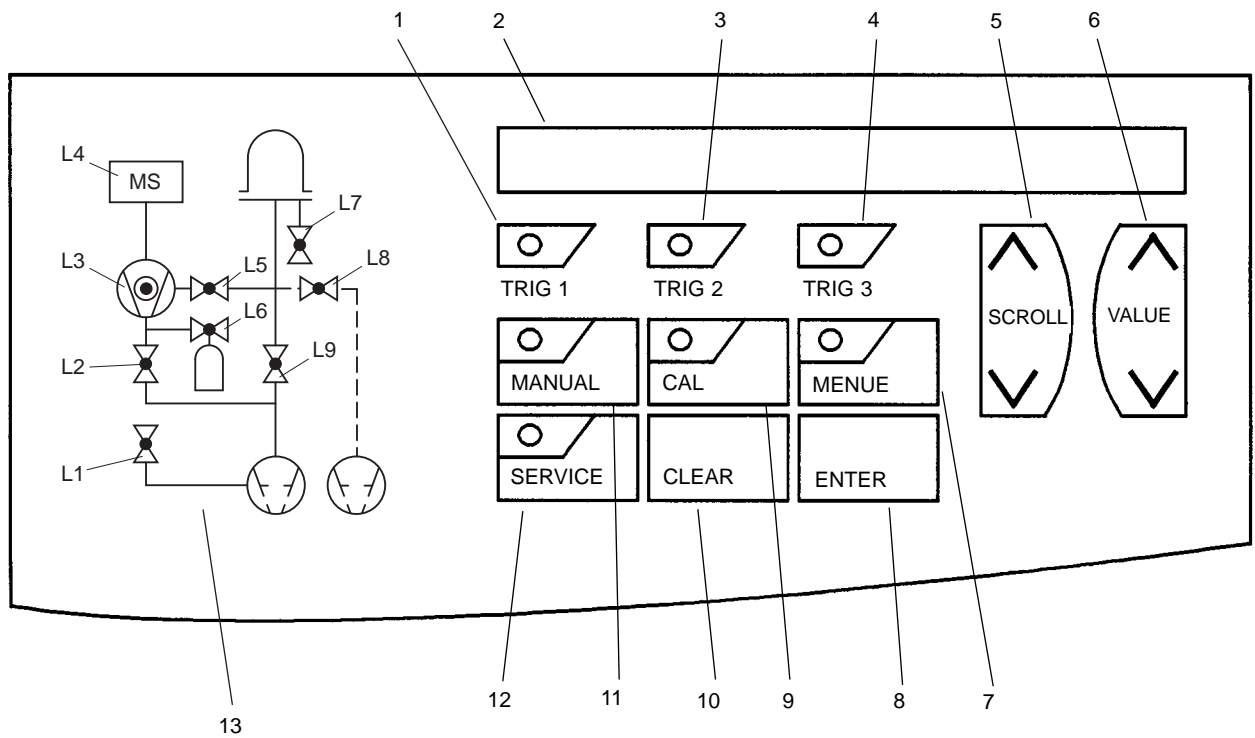

**Key to Fig. 3**

- |                     |                      |                     |                                |
|---------------------|----------------------|---------------------|--------------------------------|
| 1 LED for Trigger 1 | 4 LED for Trigger 3  | 7 MENU push-button  | 10 CLEAR push-button           |
| 2 LCD display       | 5 SCROLL push-button | 8 ENTER push-button | 11 MANUAL push-button          |
| 3 LED for Trigger 2 | 6 VALUE push-button  | 9 CAL push-button   | 12 SERVICE push-button         |
|                     |                      |                     | 13 Vacuum diagram (simplified) |

Fig. 3 Control panel

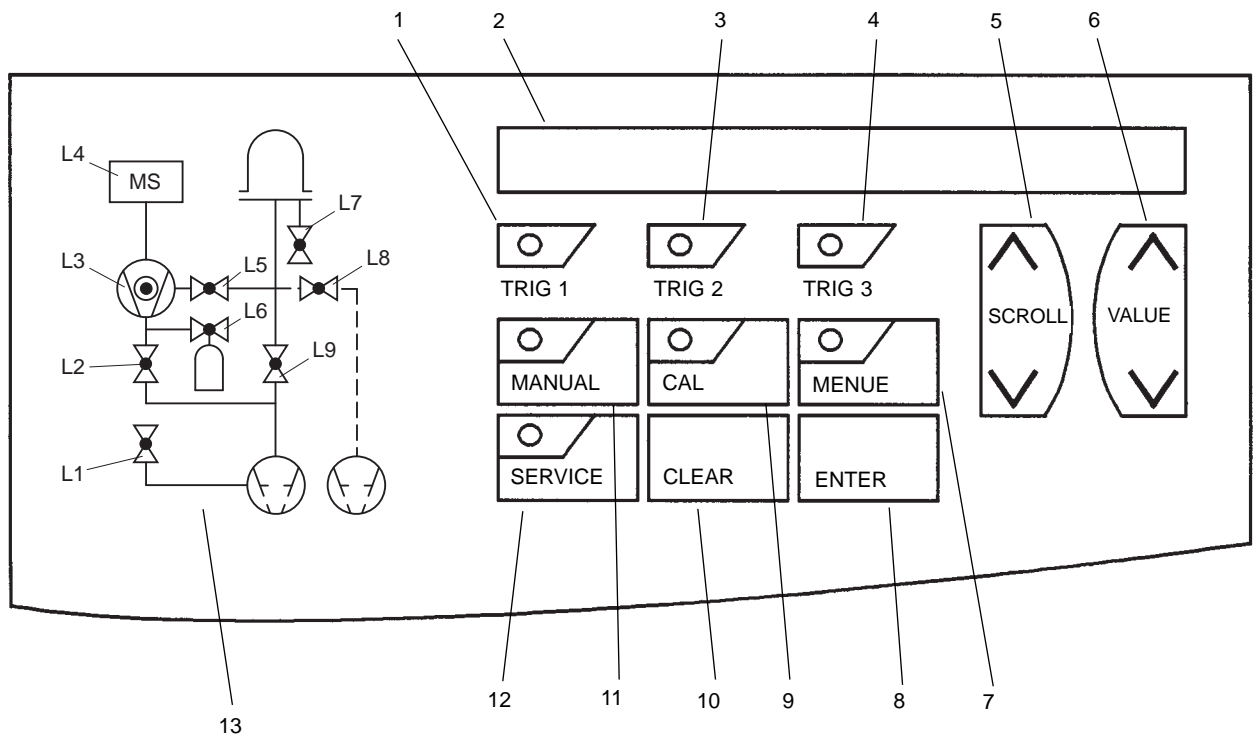

**Key to Fig. 3**

- |                     |                      |                     |                                |
|---------------------|----------------------|---------------------|--------------------------------|
| 1 LED for Trigger 1 | 4 LED for Trigger 3  | 7 MENU push-button  | 10 CLEAR push-button           |
| 2 LCD display       | 5 SCROLL push-button | 8 ENTER push-button | 11 MANUAL push-button          |
| 3 LED for Trigger 2 | 6 VALUE push-button  | 9 CAL push-button   | 12 SERVICE push-button         |
|                     |                      |                     | 13 Vacuum diagram (simplified) |

Fig. 3 Control panel

---

leak, the internal calibration mode is terminated and a corresponding error message will appear.

When the UL 200 is in the measurement mode (i.e. „Start“), pressing of „Cal“ starts an **external calibration**, i.e. the UL 200 is calibrated with the aid of a separate calibrated leak which is connected to the test sample. This process is semi-automatic. The UL 200 will tell you what to do.

#### **The „Menu“ push-button**

This push-button (3/7) is used to invoke the software menu. The UL 200 will display that menu line which was selected before.

The menu of the UL 200 is divided into three parts:

- the basic menu where the trigger thresholds (line 1 of the menu), the operating mode (line 2 of the menu), the electrical gas ballast (line 3) or a mass test (line 4) may be defined or run
- the extended menu which is only used on rare occasions and in which user-related adjustments can be made. This menu is only accessible after having entered a password in the basic menu
- the service menu which will provide you or the Inficon service technician with detailed information on the condition of the instrument.

The „scroll“ push-button (3/5) on the control panel may be used to move up and down within the menu. Within a menu line the push-buttons „Enter“ (3/8) and „Clear“

(1/10) may be operated to select the various values. This value will then flash. The flashing value may be changed by operating the „Value“ push-button (1/6) and acknowledged by pressing the „Enter“ push-button.

Pressing the „Menu“ push-button (3/7) once more exits the software menu.

#### **The „Service“ push-button**

Through the „Service“ push-button (3/12) you may select the service part of the software menu directly, provided the password has been set in the basic menu.

#### **The „Clear“ push-button**

With this push-button (3/10) you may cancel incorrect entries, interrupt processes (such as calibration) and acknowledge alarm messages.

#### **The „Enter“ push-button**

Every entry must be acknowledged by operating this push-button. Otherwise the newly entered value will not be accepted.

---

leak, the internal calibration mode is terminated and a corresponding error message will appear.

When the UL 200 is in the measurement mode (i.e. „Start“), pressing of „Cal“ starts an **external calibration**, i.e. the UL 200 is calibrated with the aid of a separate calibrated leak which is connected to the test sample. This process is semi-automatic. The UL 200 will tell you what to do.

#### **The „Menu“ push-button**

This push-button (3/7) is used to invoke the software menu. The UL 200 will display that menu line which was selected before.

The menu of the UL 200 is divided into three parts:

- the basic menu where the trigger thresholds (line 1 of the menu), the operating mode (line 2 of the menu), the electrical gas ballast (line 3) or a mass test (line 4) may be defined or run
- the extended menu which is only used on rare occasions and in which user-related adjustments can be made. This menu is only accessible after having entered a password in the basic menu
- the service menu which will provide you or the Inficon service technician with detailed information on the condition of the instrument.

The „scroll“ push-button (3/5) on the control panel may be used to move up and down within the menu. Within a menu line the push-buttons „Enter“ (3/8) and „Clear“

(1/10) may be operated to select the various values. This value will then flash. The flashing value may be changed by operating the „Value“ push-button (1/6) and acknowledged by pressing the „Enter“ push-button.

Pressing the „Menu“ push-button (3/7) once more exits the software menu.

#### **The „Service“ push-button**

Through the „Service“ push-button (3/12) you may select the service part of the software menu directly, provided the password has been set in the basic menu.

#### **The „Clear“ push-button**

With this push-button (3/10) you may cancel incorrect entries, interrupt processes (such as calibration) and acknowledge alarm messages.

#### **The „Enter“ push-button**

Every entry must be acknowledged by operating this push-button. Otherwise the newly entered value will not be accepted.

## 5 Connections

The mechanical and electrical connections are located separately at the face sides of the instrument.

The mechanical connections are used to admit and remove the gases. With the aid of the supplied elbow joint it is easily possible to attach plastic tubes (6 mm outside dia. and 4 mm inside dia.)

The connections are assigned as follows (from top to bottom):

- Exhaust
- Venting gas connection with silencer
- Gas ballast connection

The UL 200 is equipped with four multi-way connectors for the purpose of electrical communication:

- **SERIAL:** RS 232 interface (15 way) to control the UL 200 via a PC or for connecting a printer.
- **RECORD:** chart recorder output, two-channels, 0 to 10 V.
- **CONTROL:** inputs and outputs for sensing of the four relay positions and to control the UL 200 through analogue start and stop signals.
- **OPTION:** connections for driving INFICON accessories (partial flow valve, for example).

The mating connectors which are also supplied, may be used to provide the corresponding connections. Number-

ring for the sockets / plugs is from bottom to top (except for SERIAL).

The pins of the connectors have been assigned exactly as follows:

### RS 232 interface (SERIAL)

This interface has been wired as a data transfer device DCE Data Communication Equipment (modem, for example). See also Section SB 10.211 Description of the interface.

Pin	Assignment
1	Shield connection
2	TxD, data <b>to</b> UL 200
3	RxD, data <b>from</b> UL 200
4	RTS, connected unit (PC, terminal etc.) is ready to receive
5	CTS, UL 200 is ready to receive
6	DSR, UL 200 is ready
7	Reference potential (signal ground)
8	DCD, carrier signal from modem is present
20	DTR, PC is ready
22	RI, Modem is signalling an incoming call

## 5 Connections

The mechanical and electrical connections are located separately at the face sides of the instrument.

The mechanical connections are used to admit and remove the gases. With the aid of the supplied elbow joint it is easily possible to attach plastic tubes (6 mm outside dia. and 4 mm inside dia.)

The connections are assigned as follows (from top to bottom):

- Exhaust
- Venting gas connection with silencer
- Gas ballast connection

The UL 200 is equipped with four multi-way connectors for the purpose of electrical communication:

- **SERIAL:** RS 232 interface (15 way) to control the UL 200 via a PC or for connecting a printer.
- **RECORD:** chart recorder output, two-channels, 0 to 10 V.
- **CONTROL:** inputs and outputs for sensing of the four relay positions and to control the UL 200 through analogue start and stop signals.
- **OPTION:** connections for driving INFICON accessories (partial flow valve, for example).

The mating connectors which are also supplied, may be used to provide the corresponding connections. Number-

ring for the sockets / plugs is from bottom to top (except for SERIAL).

The pins of the connectors have been assigned exactly as follows:

### RS 232 interface (SERIAL)

This interface has been wired as a data transfer device DCE Data Communication Equipment (modem, for example). See also Section SB 10.211 Description of the interface.

Pin	Assignment
1	Shield connection
2	TxD, data <b>to</b> UL 200
3	RxD, data <b>from</b> UL 200
4	RTS, connected unit (PC, terminal etc.) is ready to receive
5	CTS, UL 200 is ready to receive
6	DSR, UL 200 is ready
7	Reference potential (signal ground)
8	DCD, carrier signal from modem is present
20	DTR, PC is ready
22	RI, Modem is signalling an incoming call

**Note**

- From software version V 2.0 and later the interface is fully functional.
- A commercially available 25 way cable (pins of the same number are linked) may be used to connect the instrument to a PC. In a minimum configuration it will only be required to use pins 2, 3 and 7.

**Chart recorder outputs (RECORD)**

In the expanded menu it is possible to differently assign the chart recorder outputs. Depending on the selection, the following assignments can be set up:

a) Selected assignment: LR

Pin	Assignment
1	Leak rate, mantissa U = 0.1 V to 10 V for manual ranging U = 1 V to 10 V for automatic ranging
2	GND, reference ground
3	GND, reference ground
4	Leak rate, exponent (step function) U = 1 to 10 V; 0.5 V per decade starting at 1 V = $1 \cdot 10^{-12}$ mbar·l·s <sup>-1</sup>

b) Selected assignment: LR + PE

Pin	Assignment
1	Leak rate, logarithmic U = 1 to 10 V; 0.5 V per decade starting at 1 V = $1 \cdot 10^{-12}$ mbar·l·s <sup>-1</sup>
2	GND, reference ground
3	GND, reference ground
4	Inlet pressure PE, logarithmic U = 1 to 10 V; 0.5 V per decade starting at 1 V = $1 \cdot 10^{-3}$ mbar

c) Selected assignment: PE + PV

Pin	Assignment
1	Inlet pressure PE, logarithmic U = 1 to 10 V; 0.5 V per decade starting at 1 V = $1 \cdot 10^{-3}$ mbar
2	GND, reference ground
3	GND, reference ground
4	Forevacuum pressure PV of the TMP, logarithmic U = 1 to 10 V; 0.5 V per decade starting at 1 V = $1 \cdot 10^{-3}$ mbar

**Note**

- From software version V 2.0 and later the interface is fully functional.
- A commercially available 25 way cable (pins of the same number are linked) may be used to connect the instrument to a PC. In a minimum configuration it will only be required to use pins 2, 3 and 7.

**Chart recorder outputs (RECORD)**

In the expanded menu it is possible to differently assign the chart recorder outputs. Depending on the selection, the following assignments can be set up:

a) Selected assignment: LR

Pin	Assignment
1	Leak rate, mantissa U = 0.1 V to 10 V for manual ranging U = 1 V to 10 V for automatic ranging
2	GND, reference ground
3	GND, reference ground
4	Leak rate, exponent (step function) U = 1 to 10 V; 0.5 V per decade starting at 1 V = $1 \cdot 10^{-12}$ mbar·l·s <sup>-1</sup>

b) Selected assignment: LR + PE

Pin	Assignment
1	Leak rate, logarithmic U = 1 to 10 V; 0.5 V per decade starting at 1 V = $1 \cdot 10^{-12}$ mbar·l·s <sup>-1</sup>
2	GND, reference ground
3	GND, reference ground
4	Inlet pressure PE, logarithmic U = 1 to 10 V; 0.5 V per decade starting at 1 V = $1 \cdot 10^{-3}$ mbar

c) Selected assignment: PE + PV

Pin	Assignment
1	Inlet pressure PE, logarithmic U = 1 to 10 V; 0.5 V per decade starting at 1 V = $1 \cdot 10^{-3}$ mbar
2	GND, reference ground
3	GND, reference ground
4	Forevacuum pressure PV of the TMP, logarithmic U = 1 to 10 V; 0.5 V per decade starting at 1 V = $1 \cdot 10^{-3}$ mbar

**Control inputs and outputs (CONTROL)**

Pin	Assignment
1	Start, $U < 7\text{ V} / I = 0\text{ A}$ inactive state $U > 13\text{ V} / I = 7\text{ mA}$ active state
2	Stop, $U < 7\text{ V} / I = 0\text{ A}$ inactive state $U > 13\text{ V} / I = 7\text{ mA}$ active state
3	Zero, $U < 7\text{ V} / I = 0\text{ A}$ inactive state $U > 13\text{ V} / I = 7\text{ mA}$ active state
4	GND, reference ground for pins 1, 2 and 3
5,6,7	Relay for Trigger 1; 5 center contact; 6 normally open contact; 7 normally closed contact This relay is activated as soon as the level has dropped below the trigger threshold, i.e.
Pin	Assignment
	center contact 5 is connected to normally open contact 6.
8, 9, 10	Relay for Trigger 2
11,12,13	Relay for Trigger 3
14,15,16	Relay for the signal : Ready

**Note**

Contacts 8 to 16 have been assigned in the same way as for contacts 5 to 7.

**Option**

Pin	Assignment
1	+ 24 V, applied all the time, power supply for Inficon partial flow valve or sniffer lines
2	GND
3	+24 V, switched by the UL 200 for external venting valve
4, 5, 6 7, 8	These contacts are used in connection with Inficon accessories

**Control inputs and outputs (CONTROL)**

Pin	Assignment
1	Start, $U < 7\text{ V} / I = 0\text{ A}$ inactive state $U > 13\text{ V} / I = 7\text{ mA}$ active state
2	Stop, $U < 7\text{ V} / I = 0\text{ A}$ inactive state $U > 13\text{ V} / I = 7\text{ mA}$ active state
3	Zero, $U < 7\text{ V} / I = 0\text{ A}$ inactive state $U > 13\text{ V} / I = 7\text{ mA}$ active state
4	GND, reference ground for pins 1, 2 and 3
5,6,7	Relay for Trigger 1; 5 center contact; 6 normally open contact; 7 normally closed contact This relay is activated as soon as the level has dropped below the trigger threshold, i.e.
Pin	Assignment
	center contact 5 is connected to normally open contact 6.
8, 9, 10	Relay for Trigger 2
11,12,13	Relay for Trigger 3
14,15,16	Relay for the signal : Ready

**Note**

Contacts 8 to 16 have been assigned in the same way as for contacts 5 to 7.

**Option**

Pin	Assignment
1	+ 24 V, applied all the time, power supply for Inficon partial flow valve or sniffer lines
2	GND
3	+24 V, switched by the UL 200 for external venting valve
4, 5, 6 7, 8	These contacts are used in connection with Inficon accessories

## 6 Short description of the software menu of the UL 200

No.	Indication	Subdivision 1	Subdivision 2	Description of the menu point
01	Trigger	1, 2 or 3		Here three threshold values can be defined controlling three related relays.
02	Mode	Vacuum Sniff P. Flow	normal QT normal oilfree	Definition of the operating mode: The UL 200 can be used as vacuum leak detector, sniffer leak detector or vacuum leak detector with integrated partial flow pumping set.
03	Gasballast	closed opened auto		Switching on, switching off or automatic function of the gas ballast device.
04	Test	< Enter >		Quick test in order to find out if an indicated signal is really produced by helium or just by a high background signal (H <sub>2</sub> , f. ex.).
05 - 08	free menu lines			
09	Password 1			By means of password no.1 further access to line 10 to 49 can be permitted / locked.
10	Evac. Time	1 2		By T1 and T2 it can be defined how much time it can take during evacuation for attaining the pressures $p_1 = 100$ mbar (gross leak detection) and $p_2 = 2$ mbar.

## 6 Short description of the software menu of the UL 200

No.	Indication	Subdivision 1	Subdivision 2	Description of the menu point
01	Trigger	1, 2 or 3		Here three threshold values can be defined controlling three related relays.
02	Mode	Vacuum Sniff P. Flow	normal QT normal oilfree	Definition of the operating mode: The UL 200 can be used as vacuum leak detector, sniffer leak detector or vacuum leak detector with integrated partial flow pumping set.
03	Gasballast	closed opened auto		Switching on, switching off or automatic function of the gas ballast device.
04	Test	< Enter >		Quick test in order to find out if an indicated signal is really produced by helium or just by a high background signal (H <sub>2</sub> , f. ex.).
05 - 08	free menu lines			
09	Password 1			By means of password no.1 further access to line 10 to 49 can be permitted / locked.
10	Evac. Time	1 2		By T1 and T2 it can be defined how much time it can take during evacuation for attaining the pressures $p_1 = 100$ mbar (gross leak detection) and $p_2 = 2$ mbar.

No.	Indication	Subdivision 1	Subdivision 2	Description of the menu point
11	Sensitivity	normal high		At „high“ the measuring signal is averaged for a longer time in order to obtain a balanced out indication especially in case of small leak rates. As from software version V1.4 „high“ can only be reached in the measuring ranges $10^{-10}$ resp. $10^{-11}$ mbar·l·s <sup>-1</sup> .
12	LCD-Display	LR + Unit LR + PE PE + PV		At this point it can be determined, which measuring values are indicated on the control panel: a) only the leak rate with unit of measure b) the leak rate and the inlet pressure c) the inlet pressure and the backing pressure.
13	Recorder	LR LR + PE LR + PV		Here the signals at the two channels of the printer output can be determined.
14	Control by	Keyboard   RS 232  Ext. Signal	1  2  3	All keys of the leak detector and the remote control unit are functioning. The key „CAL“ is locked. It is not possible to make any modifications in the standard menu (line 1 to4). The standard and service menu can only be entered by entering of the passwords once again. The keys CAL, MANUAL and ZERO are locked. Otherwise like „Control by keyboard 2“. The UL 200 is only controlled by a PC. All keys are locked. The UL 200 is controlled by the contacts of the „Control“-socket.

GA 10.211/4.02 - 08/00

15

No.	Indication	Subdivision 1	Subdivision 2	Description of the menu point
11	Sensitivity	normal high		At „high“ the measuring signal is averaged for a longer time in order to obtain a balanced out indication especially in case of small leak rates. As from software version V1.4 „high“ can only be reached in the measuring ranges $10^{-10}$ resp. $10^{-11}$ mbar·l·s <sup>-1</sup> .
12	LCD-Display	LR + Unit LR + PE PE + PV		At this point it can be determined, which measuring values are indicated on the control panel: a) only the leak rate with unit of measure b) the leak rate and the inlet pressure c) the inlet pressure and the backing pressure.
13	Recorder	LR LR + PE LR + PV		Here the signals at the two channels of the printer output can be determined.
14	Control by	Keyboard   RS 232  Ext. Signal	1  2  3	All keys of the leak detector and the remote control unit are functioning. The key „CAL“ is locked. It is not possible to make any modifications in the standard menu (line 1 to4). The standard and service menu can only be entered by entering of the passwords once again. The keys CAL, MANUAL and ZERO are locked. Otherwise like „Control by keyboard 2“. The UL 200 is only controlled by a PC. All keys are locked. The UL 200 is controlled by the contacts of the „Control“-socket.

GA 10.211/4.02 - 08/00

15

No.	Indication	Subdivision 1	Subdivision 2	Description of the menu point
15	RS 232	Mode  Baudrate Databits Stopbits Parity End Sign Handshake	Printer Computer	In this menu point the parameters for the communication with a printer, computer or modem are defined.
16	Relay 4 mode	Ready Error		Determination if the 4th relay is actuated in case the UL 200 is operable or at fault indication.
17	free			
18	Alarm Trigger	on off		Choice if there is an audible signal only above the leak rate defined with regard to trigger 1 or if in all measuring ranges the frequency of the audible signal is controlled proportionally to the leak rate.
19	LCD contrast	1 ..... 15		Contrast adjustment of the front panel.
20	free			
21	System BG Display	on off		Choice if at „Stand-by“ resp. „Vent“ the internal helium background or the chosen limit of detection of the leak detector is indicated.
22	Vent delay	0, 1, 1.5, 2 or „no vent“		Choice of time delay the UL 200 is vented when pressing the Stop / Vent key.
23	System integration	on off		Behaviour of the UL 200 when switched off with respect to the venting of the inlet area.

16

GA 10.211/4.02 - 08/00

No.	Indication	Subdivision 1	Subdivision 2	Description of the menu point
15	RS 232	Mode  Baudrate Databits Stopbits Parity End Sign Handshake	Printer Computer	In this menu point the parameters for the communication with a printer, computer or modem are defined.
16	Relay 4 mode	Ready Error		Determination if the 4th relay is actuated in case the UL 200 is operable or at fault indication.
17	free			
18	Alarm Trigger	on off		Choice if there is an audible signal only above the leak rate defined with regard to trigger 1 or if in all measuring ranges the frequency of the audible signal is controlled proportionally to the leak rate.
19	LCD contrast	1 ..... 15		Contrast adjustment of the front panel.
20	free			
21	System BG Display	on off		Choice if at „Stand-by“ resp. „Vent“ the internal helium background or the chosen limit of detection of the leak detector is indicated.
22	Vent delay	0, 1, 1.5, 2 or „no vent“		Choice of time delay the UL 200 is vented when pressing the Stop / Vent key.
23	System integration	on off		Behaviour of the UL 200 when switched off with respect to the venting of the inlet area.

16

GA 10.211/4.02 - 08/00

No.	Indication	Subdivision 1	Subdivision 2	Description of the menu point
24	Request for CAL	on off		Choice if the user is reminded of a necessary calibration or not.
25	Mass	2, 3 or 4		Choice of the detected mass (helium = 4).
26		Date Time		Entry of date and time.
27		Language english		Choice of German or English language.
28	Power Frequency	50 Hz 60 Hz		Entry of the frequency of the supply voltage.
29	Pumping Speed	16 ... 80 m <sup>3</sup> /h		Input of the pumping speed of the partial flow pumping set.
30	Cal leak	1.0 ... 9.9 E-7 mbar·l·s <sup>-1</sup>		Input of the leak rate of the built-in calibrated leak standard.
31-48	still free			
49	Change Password 1			Change of the password in line 9 by entry of the old and the new one afterwards.
50	Password 2	wrong right		By password no. 2 the access to the menu lines 51 to 99 can be permitted / locked.
51	UL2Vx.x D9xxxxxx			Display: software version and serial number.
52	x E xx date+time x W xx date+time			Display of the last ten fault indications and warnings.
53	Status → RS 232	<Enter>		Transmission of a status report to the RS 232-interface.

GA 10.211/4.02 - 08/00

17

No.	Indication	Subdivision 1	Subdivision 2	Description of the menu point
24	Request for CAL	on off		Choice if the user is reminded of a necessary calibration or not.
25	Mass	2, 3 or 4		Choice of the detected mass (helium = 4).
26		Date Time		Entry of date and time.
27		Language english		Choice of German or English language.
28	Power Frequency	50 Hz 60 Hz		Entry of the frequency of the supply voltage.
29	Pumping Speed	16 ... 80 m <sup>3</sup> /h		Input of the pumping speed of the partial flow pumping set.
30	Cal leak	1.0 ... 9.9 E-7 mbar·l·s <sup>-1</sup>		Input of the leak rate of the built-in calibrated leak standard.
31-48	still free			
49	Change Password 1			Change of the password in line 9 by entry of the old and the new one afterwards.
50	Password 2	wrong right		By password no. 2 the access to the menu lines 51 to 99 can be permitted / locked.
51	UL2Vx.x D9xxxxxx			Display: software version and serial number.
52	x E xx date+time x W xx date+time			Display of the last ten fault indications and warnings.
53	Status → RS 232	<Enter>		Transmission of a status report to the RS 232-interface.

GA 10.211/4.02 - 08/00

17

No.	Indication	Subdivision 1	Subdivision 2	Description of the menu point
54	Scan to Rec	<Enter>		Transmission of a mass spectrum for the printer output.
55	Info	PE PV Electronic Amplifier TMP TMP State Anod-Cat Anode Battery Rem. Cont. Ext. Supp. Volt Reference Control Inp.		By this menu point several internal measuring values can be indicated: - inlet and backing pressure in mbar - temperatures of the electr. board and of the preamplifier - number of rotations and state of the TMP - difference in voltage of anode and cathode - voltages of anode, battery, remote control, at pin no. 1 of the OPTION plug - reference voltage - state of remote control inputs.
56	Cycles	V1, V2a, V2b, V3, V4, V4.1,		Indication of the operation cycle of the valves.
57	Operat. time			Indication of the working hours.
58	Task	0x,0x,0x		Indication of the process status.
59		Offset Factor Fine Factor G/F Factor Resistor Factor S N Factor S QT		Indication of characteristic values for the leak rate calculation.

No.	Indication	Subdivision 1	Subdivision 2	Description of the menu point
54	Scan to Rec	<Enter>		Transmission of a mass spectrum for the printer output.
55	Info	PE PV Electronic Amplifier TMP TMP State Anod-Cat Anode Battery Rem. Cont. Ext. Supp. Volt Reference Control Inp.		By this menu point several internal measuring values can be indicated: - inlet and backing pressure in mbar - temperatures of the electr. board and of the preamplifier - number of rotations and state of the TMP - difference in voltage of anode and cathode - voltages of anode, battery, remote control, at pin no. 1 of the OPTION plug - reference voltage - state of remote control inputs.
56	Cycles	V1, V2a, V2b, V3, V4, V4.1,		Indication of the operation cycle of the valves.
57	Operat. time			Indication of the working hours.
58	Task	0x,0x,0x		Indication of the process status.
59		Offset Factor Fine Factor G/F Factor Resistor Factor S N Factor S QT		Indication of characteristic values for the leak rate calculation.

No.	Indication	Subdivision 1	Subdivision 2	Description of the menu point
60-69	free			
70	Automatic	on off		Switching on / off of the automatic functions is only possible if password no. 2 was entered.
71	Valve supply	auto  high		Valves are actuated by a 24 V pulse and 7.8V with stand voltage afterwards. Valves are actuated by 24 V continuous voltage.
72	xxxxx	V x		Manual operation of the different valves.
73	Emission	on off		Manual switching on / off of the emission.
74	Anode	M4 M3 M2	xxx V xxx V xxx V	Manual mass adjustment.
75	Amp	EMI off	13M 470 M 15G 500G	Indication of the preamplifier voltages of different working resistances.
76	Gain	A  M		Indication of the current power amplifying factors and the corresponding voltage of the analog-digital converters.
77	Cathode	1 2		Choice between cathode no. 1 and no. 2.
78	Unit	mbar·l·s <sup>-1</sup> Pa m <sup>3</sup> ·s <sup>-1</sup>		Choice of leak rate and pressure unit.

GA 10.211/4.02 - 08/00

19

No.	Indication	Subdivision 1	Subdivision 2	Description of the menu point
60-69	free			
70	Automatic	on off		Switching on / off of the automatic functions is only possible if password no. 2 was entered.
71	Valve supply	auto  high		Valves are actuated by a 24 V pulse and 7.8V with stand voltage afterwards. Valves are actuated by 24 V continuous voltage.
72	xxxxx	V x		Manual operation of the different valves.
73	Emission	on off		Manual switching on / off of the emission.
74	Anode	M4 M3 M2	xxx V xxx V xxx V	Manual mass adjustment.
75	Amp	EMI off	13M 470 M 15G 500G	Indication of the preamplifier voltages of different working resistances.
76	Gain	A  M		Indication of the current power amplifying factors and the corresponding voltage of the analog-digital converters.
77	Cathode	1 2		Choice between cathode no. 1 and no. 2.
78	Unit	mbar·l·s <sup>-1</sup> Pa m <sup>3</sup> ·s <sup>-1</sup>		Choice of leak rate and pressure unit.

GA 10.211/4.02 - 08/00

19

No.	Indication	Subdivision 1	Subdivision 2	Description of the menu point
79	Default Reset	<Enter>		Reset of the parameters of the menu lines 1, 2, 3, 9, 10 to 25 and 49 to standard values.
80-89	free			
90	AMP Test	<Enter>		Automatic self-test of the preamplifier.
91	Burn In	<Enter>		Continous test of the leak detector. Finishing by „Clear“.
92	Adjust	Resistor Gross/Fine Thermovac		Automatic adjustment of several parts of the UL 200 (preamplifier, vacuum system, pressure gauges (semiautomatically))
93 -98	free			
99	Change Password 2			Change of password in line 49 by entry of the old and new one afterwards.

No.	Indication	Subdivision 1	Subdivision 2	Description of the menu point
79	Default Reset	<Enter>		Reset of the parameters of the menu lines 1, 2, 3, 9, 10 to 25 and 49 to standard values.
80-89	free			
90	AMP Test	<Enter>		Automatic self-test of the preamplifier.
91	Burn In	<Enter>		Continous test of the leak detector. Finishing by „Clear“.
92	Adjust	Resistor Gross/Fine Thermovac		Automatic adjustment of several parts of the UL 200 (preamplifier, vacuum system, pressure gauges (semiautomatically))
93 -98	free			
99	Change Password 2			Change of password in line 49 by entry of the old and new one afterwards.

---

## 7 Vacuum Leak Detection Method

First read Section 3.

Please convince yourself that the UL 200 is running in the „Vent“ or „Standby“ mode.

Also convince yourself that the leak detector has been set to the vacuum leak detection mode (menu line 2).

Connect the test object to the UL 200 and start the measurement process („Start“ push-button (2/3) on the hand unit).

After evacuation of the test sample and after a sufficiently low operating pressure has been attained ( $PE < 2$  mbar), the UL 200 will automatically switch to the measurement mode. The leak rate which is measured, coming from the helium component of the air initially present in the instrument, is then digitally displayed on the LCD display on the control panel and also by the light bar on the hand unit. When the leak rate is sufficiently low, the test sample may be leak tested by spraying it with helium.

GA 10.211/4.02 - 08/00

## 8 Sniffer Leak Detection Method

First read Section 3.

For implementing the sniffer leak detection method, first connect a sniffer line to the inlet flange on the UL 200. The following components from the INFICON range may be used:

- a) the UL 200 sniffer lines (Cat. Nos. 140 21 and 140 24)
- b) the quick sniffer QT 100 (155 94) including sniffer line (Cat. No. 155 77 and 155 76)
- c) the simple sniffer which is supplied (Ref. No. 200 28 787)  
(Due to its simple design, this sniffer line is only suitable for sporadic sniffer leak tests. Should thus not be used for repeated/continuous measurements).

Select the „Sniff“ operating mode in the menu (line 2) and also select the type of sniffer line which has been connected: „ST“ for a sniffer line according to according to a) or c) and „QT“ when using the QT 100 (see b).

When using the QT 100, this sniffer must also be connected to a power supply.

Press „Start“ (2/3) on the hand unit. After a few seconds the UL 200 is ready to take measurements and you may begin to detect leaks with the sniffer on the test sample which is pressurised with helium.

21

---

## 7 Vacuum Leak Detection Method

First read Section 3.

Please convince yourself that the UL 200 is running in the „Vent“ or „Standby“ mode.

Also convince yourself that the leak detector has been set to the vacuum leak detection mode (menu line 2).

Connect the test object to the UL 200 and start the measurement process („Start“ push-button (2/3) on the hand unit).

After evacuation of the test sample and after a sufficiently low operating pressure has been attained ( $PE < 2$  mbar), the UL 200 will automatically switch to the measurement mode. The leak rate which is measured, coming from the helium component of the air initially present in the instrument, is then digitally displayed on the LCD display on the control panel and also by the light bar on the hand unit. When the leak rate is sufficiently low, the test sample may be leak tested by spraying it with helium.

GA 10.211/4.02 - 08/00

## 8 Sniffer Leak Detection Method

First read Section 3.

For implementing the sniffer leak detection method, first connect a sniffer line to the inlet flange on the UL 200. The following components from the INFICON range may be used:

- a) the UL 200 sniffer lines (Cat. Nos. 140 21 and 140 24)
- b) the quick sniffer QT 100 (155 94) including sniffer line (Cat. No. 155 77 and 155 76)
- c) the simple sniffer which is supplied (Ref. No. 200 28 787)  
(Due to its simple design, this sniffer line is only suitable for sporadic sniffer leak tests. Should thus not be used for repeated/continuous measurements).

Select the „Sniff“ operating mode in the menu (line 2) and also select the type of sniffer line which has been connected: „ST“ for a sniffer line according to according to a) or c) and „QT“ when using the QT 100 (see b).

When using the QT 100, this sniffer must also be connected to a power supply.

Press „Start“ (2/3) on the hand unit. After a few seconds the UL 200 is ready to take measurements and you may begin to detect leaks with the sniffer on the test sample which is pressurised with helium.

21

---

## 9 Partial Flow Operation

First read Section 3.

For the partial flow operating mode you must first install the parts belonging to the partial flow pump set from Inficon (see also Operating Instruction GA 10.277 „Partial flow system for UL 200“).

- a) Fit the valve block with the O-ring gasket to the inlet flange and secure it with a clamping ring.
- b) Fit one side of the solenoid valve to the valve block. Please connect the other side of the valve to the vacuum hose, which in turn must be connected to the rotary vane vacuum pump.
- c) Connect the control cable of the valve to the „Options“ socket.
- d) Connect the rotary vane vacuum pump and the valve to the mains and switch the pump on.
- e) Select „part.flow“ in the menu of the UL 200 (line 2). If you must prevent the possibility of oil backstreaming from the partial flow pump into the test sample under all circumstances, select „oil-free“ in the same line of the menu; otherwise use the „normal“ setting.

After these preparations, operation of the UL 200 will be the same as for normal operation of the leak detector (see Section 7). Connect the test sample to the remain-

22

ing flange of the valve block - using a further piece of vacuum tubing, if required - and start the measurement process.

### Note

Switching of the partial flow valve can cause sudden banging noises. This is normal and not a malfunction in any way.

## 10 Switching the Instrument Off

The UL 200 may be switched off at any time regardless of the mode it is in.

The vacuum system of the UL 200 is vented automatically.

Additional components (like QT 100, partial flow pump etc.) will have to be switched off separately.

---

## 9 Partial Flow Operation

First read Section 3.

For the partial flow operating mode you must first install the parts belonging to the partial flow pump set from Inficon (see also Operating Instruction GA 10.277 „Partial flow system for UL 200“).

- a) Fit the valve block with the O-ring gasket to the inlet flange and secure it with a clamping ring.
- b) Fit one side of the solenoid valve to the valve block. Please connect the other side of the valve to the vacuum hose, which in turn must be connected to the rotary vane vacuum pump.
- c) Connect the control cable of the valve to the „Options“ socket.
- d) Connect the rotary vane vacuum pump and the valve to the mains and switch the pump on.
- e) Select „part.flow“ in the menu of the UL 200 (line 2). If you must prevent the possibility of oil backstreaming from the partial flow pump into the test sample under all circumstances, select „oil-free“ in the same line of the menu; otherwise use the „normal“ setting.

After these preparations, operation of the UL 200 will be the same as for normal operation of the leak detector (see Section 7). Connect the test sample to the remain-

22

ing flange of the valve block - using a further piece of vacuum tubing, if required - and start the measurement process.

### Note

Switching of the partial flow valve can cause sudden banging noises. This is normal and not a malfunction in any way.

## 10 Switching the Instrument Off

The UL 200 may be switched off at any time regardless of the mode it is in.

The vacuum system of the UL 200 is vented automatically.

Additional components (like QT 100, partial flow pump etc.) will have to be switched off separately.

GA 10.211/4.02 - 08/00

GA 10.211/4.02 - 08/00



### Declaration of Contamination of Vacuum Equipment and Components

The repair and/or service of vacuum equipment and components will only be carried out if a correctly completed declaration has been submitted. Non-completion will result in delay. The manufacturer could refuse to accept any equipment without a declaration. This declaration can only be completed and signed by authorized and qualified staff.

**1. Description of Vacuum Equipment and Components**

- Equipment type/model: \_\_\_\_\_
- Code No.: \_\_\_\_\_
- Serial No.: \_\_\_\_\_
- Invoice No.: \_\_\_\_\_
- Delivery date: \_\_\_\_\_

**2. Reason for Return**

\_\_\_\_\_

\_\_\_\_\_

\_\_\_\_\_

**3. Condition of the Vacuum Equipment and Components**

- Has the equipment been used?
  - yes  no
- What type of pump oil/liquid was used? \_\_\_\_\_
- Is the equipment free from potentially harmful substances?
  - yes  no  (go to Section 5)
  - no  (go to Section 4)

**4. Process related Contamination of Vacuum Equipment and Components:**

- toxic  yes  no
- corrosive  yes  no
- explosive\*  yes  no
- biological hazard\*  yes  no
- radioactive\*  yes  no
- other harmful substances  yes  no

\* Vacuum equipment and components which have been contaminated by biological explosive or radioactive substances, will not accepted without written evidence of decontamination!

Please list all substances, gases and by-products which may have come into contact with the equipment:

Trade name Product name Manufacturer	Chemical name (or Symbol)	Dangerous material class	Measures if spillage	First aid in case of human contact
1.				
2.				
3.				
4.				
5.				

### 5. Legally Binding Declaration

I hereby declare that the information supplied on this form is complete and accurate. The despatch of the contaminated vacuum equipment and components will be in accordance with the appropriate regulations covering Packaging, Transportation and Labelling of Dangerous Substances.

Name of organisation or company: \_\_\_\_\_

Address: \_\_\_\_\_ Post code: \_\_\_\_\_

Tel.: \_\_\_\_\_

Fax: \_\_\_\_\_ Telex: \_\_\_\_\_

Name: \_\_\_\_\_

Job title: \_\_\_\_\_

Date: \_\_\_\_\_ Company stamp: \_\_\_\_\_

Legally binding signature: \_\_\_\_\_



### Declaration of Contamination of Vacuum Equipment and Components

The repair and/or service of vacuum equipment and components will only be carried out if a correctly completed declaration has been submitted. Non-completion will result in delay. The manufacturer could refuse to accept any equipment without a declaration. This declaration can only be completed and signed by authorized and qualified staff.

**1. Description of Vacuum Equipment and Components**

- Equipment type/model: \_\_\_\_\_
- Code No.: \_\_\_\_\_
- Serial No.: \_\_\_\_\_
- Invoice No.: \_\_\_\_\_
- Delivery date: \_\_\_\_\_

**2. Reason for Return**

\_\_\_\_\_

\_\_\_\_\_

\_\_\_\_\_

**3. Condition of the Vacuum Equipment and Components**

- Has the equipment been used?
  - yes  no
- What type of pump oil/liquid was used? \_\_\_\_\_
- Is the equipment free from potentially harmful substances?
  - yes  no  (go to Section 5)
  - no  (go to Section 4)

**4. Process related Contamination of Vacuum Equipment and Components:**

- toxic  yes  no
- corrosive  yes  no
- explosive\*  yes  no
- biological hazard\*  yes  no
- radioactive\*  yes  no
- other harmful substances  yes  no

\* Vacuum equipment and components which have been contaminated by biological explosive or radioactive substances, will not accepted without written evidence of decontamination!

Please list all substances, gases and by-products which may have come into contact with the equipment:

Trade name Product name Manufacturer	Chemical name (or Symbol)	Dangerous material class	Measures if spillage	First aid in case of human contact
1.				
2.				
3.				
4.				
5.				

### 5. Legally Binding Declaration

I hereby declare that the information supplied on this form is complete and accurate. The despatch of the contaminated vacuum equipment and components will be in accordance with the appropriate regulations covering Packaging, Transportation and Labelling of Dangerous Substances.

Name of organisation or company: \_\_\_\_\_

Address: \_\_\_\_\_ Post code: \_\_\_\_\_

Tel.: \_\_\_\_\_

Fax: \_\_\_\_\_ Telex: \_\_\_\_\_

Name: \_\_\_\_\_

Job title: \_\_\_\_\_

Date: \_\_\_\_\_ Company stamp: \_\_\_\_\_

Legally binding signature: \_\_\_\_\_

Copies: Page 1 (white) to manufacturer or representative - Page 2 (yellow) attach to consentment packaging securely - Page 3 (blue) copy for file of sender



---

INFICON GmbH, Bonner Straße 498 (Bayenthal), D-50968 Köln  
Telefon: (0221) 347-40    Telefax: (0221) 347-41429  
[www.inficon.com](http://www.inficon.com)

**UNITED STATES   TAIWAN   JAPAN   KOREA   SINGAPORE   GERMANY   FRANCE   UNITED KINGDOM   HONG KONG**  
Visit our website for contact information and other sales offices worldwide. **[www.inficon.com](http://www.inficon.com)**

hin a30 e1-a (0008) ©08/2000 INFICON Inc.    Printed in Germany on chlorine-free bleached paper



---

INFICON GmbH, Bonner Straße 498 (Bayenthal), D-50968 Köln  
Telefon: (0221) 347-40    Telefax: (0221) 347-41429  
[www.inficon.com](http://www.inficon.com)

**UNITED STATES   TAIWAN   JAPAN   KOREA   SINGAPORE   GERMANY   FRANCE   UNITED KINGDOM   HONG KONG**  
Visit our website for contact information and other sales offices worldwide. **[www.inficon.com](http://www.inficon.com)**

hin a30 e1-a (0008) ©08/2000 INFICON Inc.    Printed in Germany on chlorine-free bleached paper